

MINI SPECIFICATIONS

SAFE WORKING SPEEDS AT VARYING LENGTHS

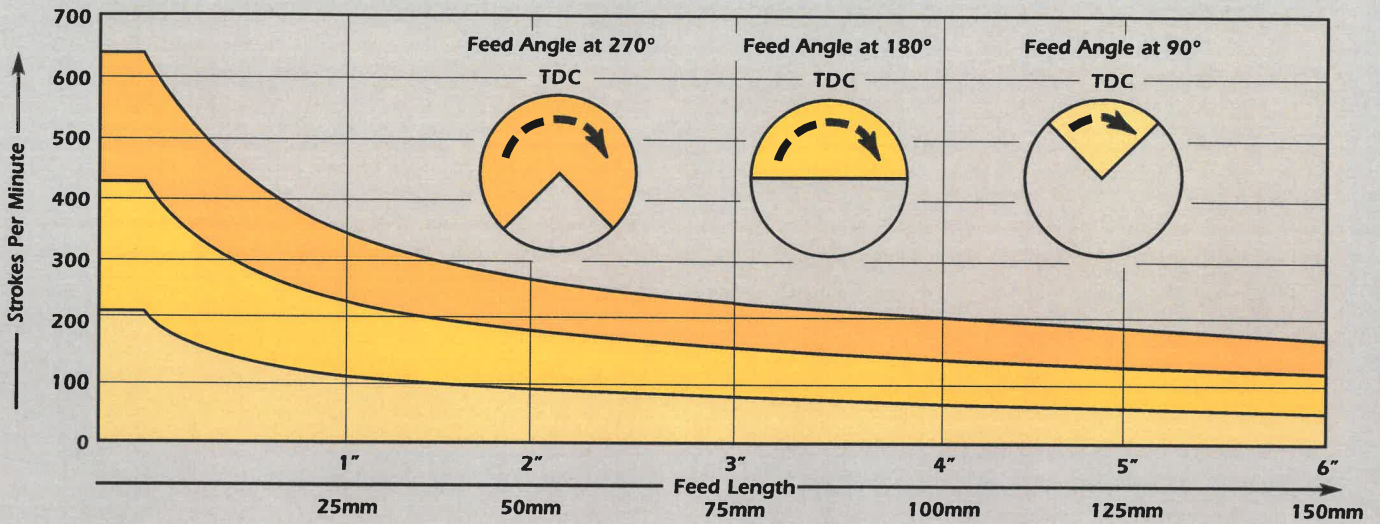

Performance data shown is for estimating purposes only. Production rates and capacities are dependent upon feed length and material. Consult P/A for specific application needs.

DIMENSIONS

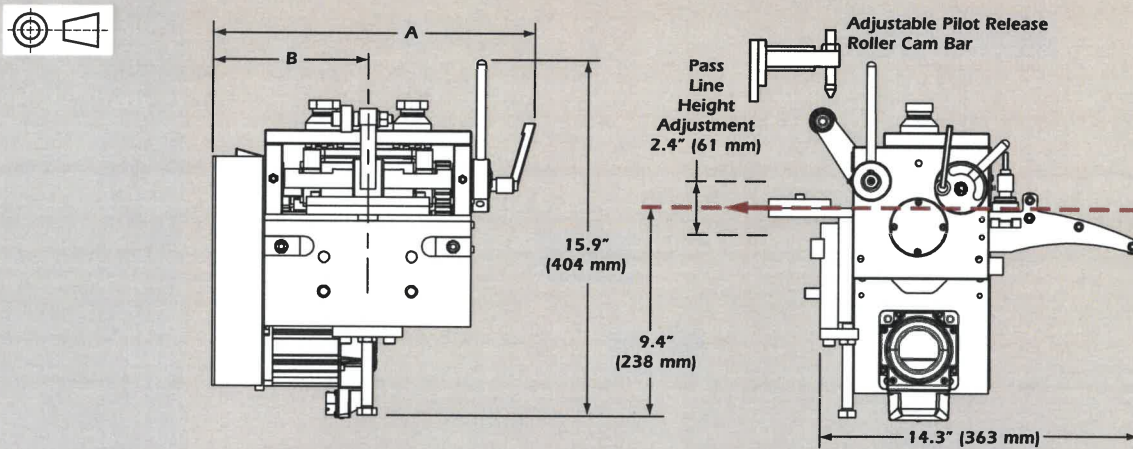

DIMENSIONS - inches

Model	A	B
SRF-105P	14.4	7.0
SRF-220P	18.9	9.1
SRF-320P	22.9	11.1

DIMENSIONS - mm

Model	A	B
SRF-105P	366	178
SRF-220P	481	231
SRF-320P	581	282

SPECIFICATIONS - USA

Model	Feed Roll Dia. in.	Max Roll Opening in.*	Full Capacity		Pulling Power		AC Power Input V/Ph/Hz	kW
			Thickness in.	at Width in.	Peak lbs.	Cont. lbs.		
SRF-105P	1.77	.078	.060	4	113	39	115/1/60	0.4
SRFX-105P	1.77	.078	.078	4	212	71	230/1/60	0.8
SRF-220P	1.77	.078	.038	8.5	113	39	115/1/60	0.4
SRFX-220P	1.77	.078	.060	8.5	212	71	230/1/60	0.8
SRF-320P	1.77	.078	.060	12.5	212	71	230/1/60	0.8

* Optional Max. Roll Opening .098 inch

SPECIFICATIONS - METRIC

Model	Feed Roll Dia. mm	Max Roll Opening mm*	Full Capacity		Pulling Power		AC Power Input V/Ph/Hz	kW
			Thickness mm	at Width mm	Peak N	Cont. N		
SRF-105P	45	2,00	1,52	105	504	172	230/1/50	0,4
SRFX-105P	45	2,00	2,00	105	943	318	230/1/50	0,8
SRF-220P	45	2,00	0,97	220	504	172	230/1/50	0,4
SRFX-220P	45	2,00	1,52	220	943	318	230/1/50	0,8
SRF-320P	45	2,00	1,52	320	943	318	230/1/50	0,8

* Optional Max. Roll Opening 2,5 mm